

CONNEX-Junction

for subsequent lateral connections to
thin-walled drainage and sewer pipes



adjustable – durable – leakproof



KANALROHRSYSTEM
Connex[®]

The product

Thanks to the CONNEX-Junction, house connection lines or lateral pipes can be quickly, easily and cost-effectively joined to the main sewer, on new or existing pipes. The component features an integrated adjustable socket. This ensures that the connected pipes permit movement in all directions, from 0° to 11°. The CONNEX-Junction thus complies with the requirements of DWA A-139, according to which "lateral pipes must be manufactured and connected so that they can allow for movement". The resulting, significant increase in flexibility contributes a great deal to newly laid house connection pipes having the desired high manufacturing standard and a long service life.



The advantages

The use of the CONNEX-Junction considerably simplifies conventional working methods: Exposing a metre-wide section of the main sewer for the subsequent connection of pipes is no longer necessary. The pipe bed remains untouched during the assembly work. Installing Y- respectively T-Junctions with slip couplers after cutting the main pipeline is also no longer required. The precise, quick fitting saves time and money. In practical terms, the CONNEX-Junction made from PVC-U has also demonstrated another advantage: If the pipe line has to undergo repairs, the "top-hat profile" is easy to attach to the CONNEX-Junction.

The versions

The CONNEX-Junction comes in three versions: 200 mm bore with 200 mm socket in the upper section for the DN/OD 250 to 1500 nominal diameter range; 200 mm bore with 160 mm socket for the DN/OD 400 to 1500 nominal diameter range and the smaller version with a 162 mm bore and 160 mm socket for the DN/OD 200 to 315 nominal diameter range, see images below. When installing two CONNEX Junctions, the distance between the connections must be at least 500 mm.



CONNEX-Junction to GRP-Pipe



Internal view of a CONNEX PVC-U DN/OD 400 sewer pipe with correctly fitted CONNEX-Junction (internal view)



CONNEX DN/OD 160/162 junction on HS® sewer pipe, 162 ± 1 mm bore

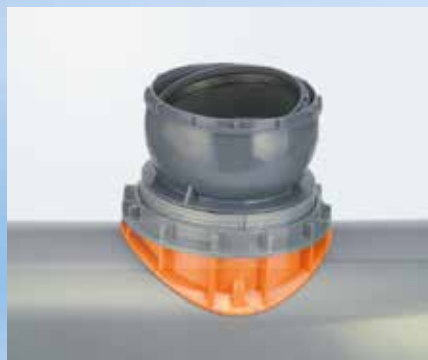

CONNEX DN/OD 160/200 junction on CONNEX sewer pipe, 200 ± 1 mm bore

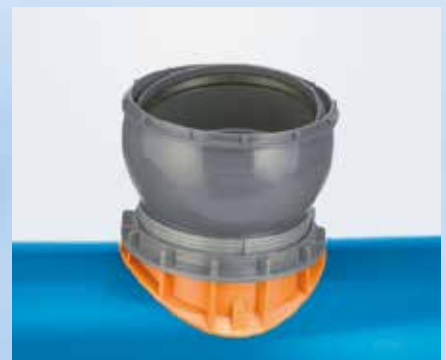

CONNEX DN/OD 200/200 junction on HS® sewer pipe, 200 ± 1 mm bore

CONNEX-Junction with adjustable socket



The groove in the junction lower section contains details of the nominal size and also the code number of the complete set.



The type number (= first 3 digits of the code no.) is visible on the inside of the Connex-Junction.



The code number for replacement orders can be found on the spacer ring.

DN Main Pipe (smooth-walled)	Internal Ø Main Pipe mm	Pipe wall thickness max. mm	Junction mm	Bore ± 1 mm	Code Junction (Set)
200	181-191	15,0	160	162	CO201.191
250	228-242	15,0	160	162	CO253.242
300	287-306	15,0	160	162	CO302.306
400	362-380	31,8	160	200	CO403.380
400	392-412	31,8	160	200	CO404.412
500	453-513	31,8	160	200	CO502.513
600	572-607	31,8	160	200	CO602.607
700-800	665-809	31,8	160	200	CO702.809
900-1500	856-1500	31,8	160	200	CO902.1212
250	226-241	31,8	200	200	CO251.241
250	249-259	31,8	200	200	CO252.259
300	275-295	31,8	200	200	CO304.295
300	295-313	31,8	200	200	CO301.313
400	362-380	31,8	200	200	CO401.380
400	392-412	31,8	200	200	CO402.412
500	453-513	31,8	200	200	CO501.513
600	572-607	31,8	200	200	CO601.607
700-800	665-809	31,8	200	200	CO701.809
900-1500	856-1500	31,8	200	200	CO901.1212



The CONNEX set consists of a junction upper and lower section, spacer ring, threaded ring and a tube of lubricant. A product information sheet with installation instructions is also supplied.

Choosing the right CONNEX-Junction depends on the internal diameter of the main pipe. For each nominal diameter there are various possible connection pipe options. Please note: There are several CONNEX-Junctions available for each of the nominal diameters DN/OD 250 up to DN/OD 400. It is important to state the appropriate code number when ordering.

The CONNEX-Junction with adjustable socket

Technical data / installation sequence

CONNEX-Junction
DN/OD 160/162

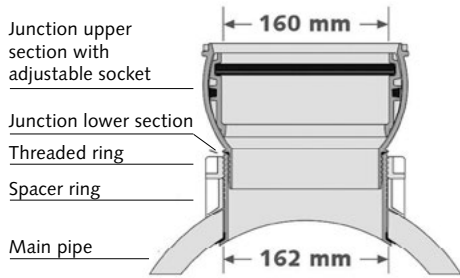

CONNEX-Junction
DN/OD 160/200

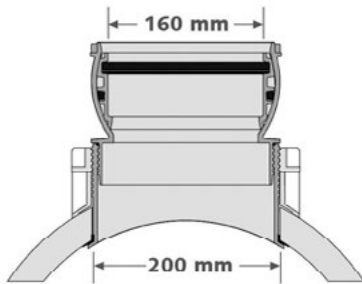

CONNEX-Anschluss
DN/OD 200/200

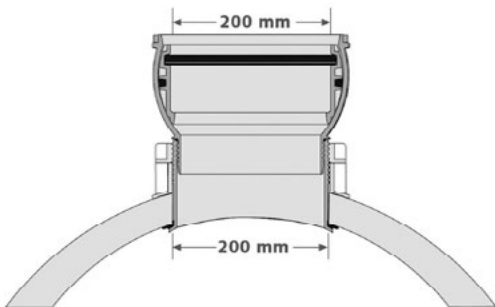

4
Junction upper section with adjustable socket



3

Threaded ring



2

Spacer ring



1

Junction lower section

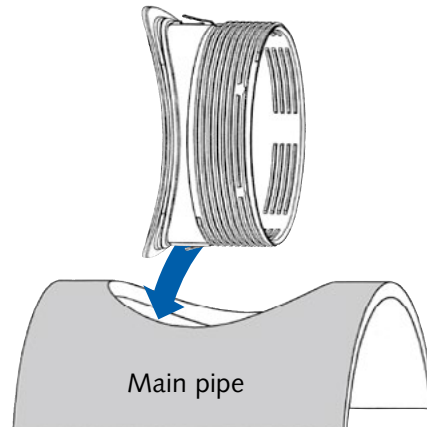

The CONNEX-Junction with adjustable socket

Junction Nominal Diameter DN/OD	Ø Bore mm	Main Pipe Nominal Diameter DN
160	162 ±1	200-315
160	200 ±1	400-1500
200	200 ±1	250-1500

CONNEX-Junction with adjustable socket



Tests and test certificates



Internal view after the Hamburg getting trials



Jetting test iro 19523



Test set-up for Hamburg getting trials



Test set-up for shear loading test



Certifications / Approvals



The CONNEX-Junction with adjustable socket

Installation instructions for the lower section DN/OD 160 and DN/OD 200

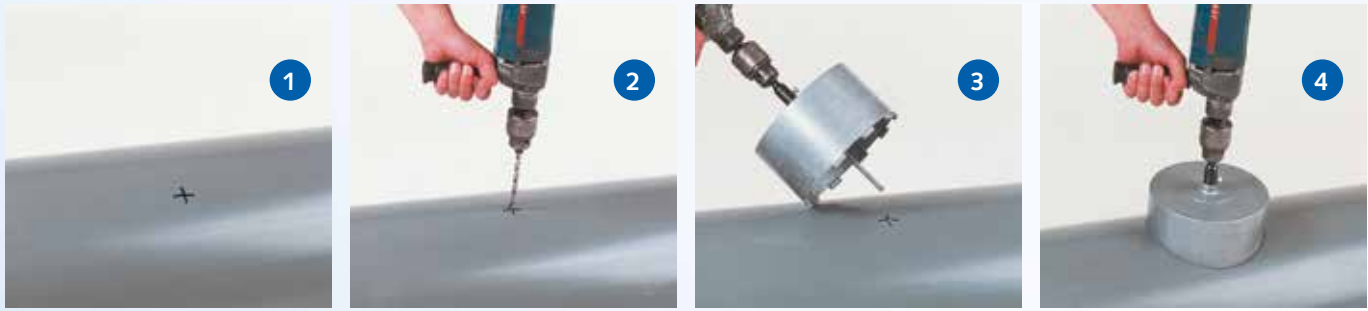

Mark the position of the installation point on the sewer pipe, in this case a CONNEX sewer pipe, using a suitable marker (1). Pre-drill the interface with an 10 mm twist drill bit (2). Fit the guide pin of the drill bit into this drilled hole (3). Drill the core centrally, at 90° to the pipe axis. During the drilling procedure, fully immerse the drill bit into the pipe cross section. By doing so, no ridges are left in the drill recess. Bore diameter: 162 or 200 mm ± 1 mm. (4). **Always ensure the drilled hole is free of splintering.**



After correctly drilling the hole, deburr edges with a suitable tool inside (5) and outside (6). Push the lower section of the CONNEX-Junction into the main pipe through the drilled hole (7-9). **Do not apply any lubricant to the lower seal.**

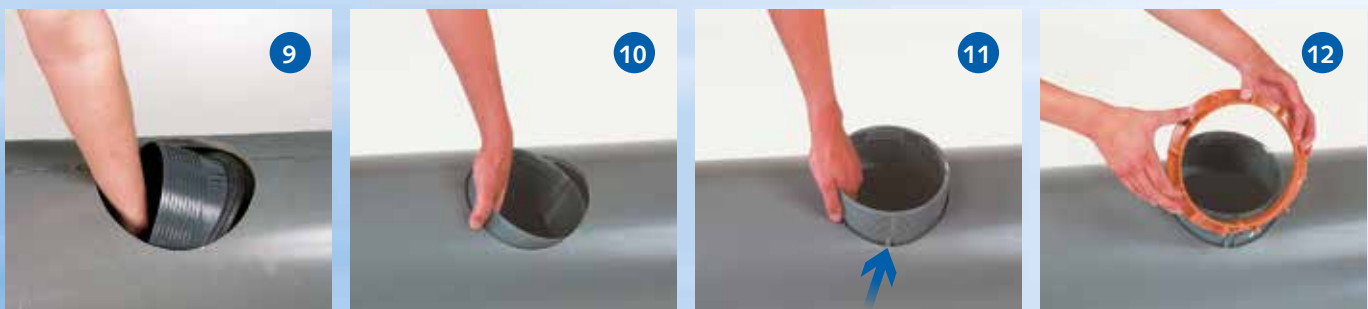

Turn the CONNEX-Junction in the main pipe and pull upwards to fit into the pipe radius (10) until the retainer clips (see arrow) (11) fold out to secure the junction. Place the red-brown coloured spacer ring onto the guide groove of the lower section (12).



Important – Centralise the lower section in the bored hole so that a uniform annular gap is produced all round (13). Apply the lubricant to the inside of the grey threaded ring (14). Position the grey threaded ring so that it is not tilted, and can be screwed easily (15). With one hand, pull up the lower part of the junction to position it on the inside radius of the main pipe. With the other hand tighten the grey threaded ring hand tight (16).

Upper section installation instructions



Installation instructions CONNEX-Junction DN/OD 160/162 Important note: A specially developed spanner insert ensures that the spanner used previously for the threaded ring (fits DN/OD 200) can still be used for all installation variants. Fit the spanner insert (white) onto the threaded ring (17). Tighten the threaded ring firmly with the corresponding spanner (available in the range) (18). This will compress the inner seal between the lower section of the junction and the main pipe. Check the lower section of the junction is correctly seated in the main pipe. Cover the O-ring and the thread of the upper section of the junction with the lubricant (19). Push the upper section of the junction (20) right into the lower section of the junction, turn it once to the left to locate the start of the thread and turn it in to the right without tilting it (21). Fit the spanner insert onto the upper section. Securely tighten the upper section of the junction down to the stop with the spanner (22). Finally, exert gentle tapping movements on the handle. Check that the junction is correctly seated in the main pipe.



Installation instructions CONNEX-Junction DN/OD 160/200 and DN/OD 200/200

Tighten the threaded ring firmly with the spanner (available in the range) (23+24). This will compress the inner seal between the lower section of the junction and the main pipe. Check the lower section of the junction is correctly seated in the main pipe. Cover the O-ring and the thread of the upper section of the junction with the lubricant (25). Push the upper section of the junction right into the lower section of the junction, turn it once to the left to locate the start of the thread (26) and turn it in to the right without tilting it (see above) (27). Fit the spanner insert onto the upper section (28). Securely tighten the upper section of the junction down to the stop with the spanner. Finally, exert gentle hitting movements on the handle (29). Check that the junction is correctly seated in the main pipe (30). **Important note: Correct installation is only possible with the spanner and the spanner insert.**

More installation tips for correct fitting: The nominal diameter, junction type and inside diameter given in the guide groove of the CONNEX-Junction are to be checked before installation and compared with the inside diameter of the main pipe (31). Likewise, the correct seating of the spacer ring must be checked again after fitting the lower section. **Important note: The spacer ring must be firmly seated against the main pipe.**

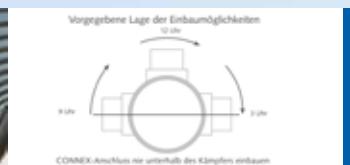

CONNEX-Junction

with adjustable socket

DN/OD 160 and 200 mm

The advantages

- Lateral connection free from tension
- Pipe joints adjustable from 0° to 11°
- Complies with the requirements of DWA A-139
- Variable adaptation to wall thicknesses from 3.0 to 31.8 mm
- Quick, easy and adjustable, both for pre- or post-construction connections
- Particularly suitable for areas prone to subsidence or increased ground movement
- Vast savings on installation due to reduced excavation at the point of pipeline modification, meaning installation of fittings such as slip couplers, junctions, and pipe sections on the main pipe is not required
- Connection of all standard lateral sewage and drainage pipes DN/OD 160 and 200 possible
- For smooth-walled main pipes from DN 200 to DN 1500
- Reduced amounts of excavated soil due to space-saving installation
- Pressure tested to 0.5 bar
- No disruption to pipe bedding during installation
- No misalignment in the pipeline
- Easier, faster installation of lateral pipes due to adjustable socket
- No interruption to sewerage operations during installation
- With DIBt approval, Z-42.1-376 (Germany)
- With WRc approval PT/435/0119 (UK)



Junction upper section
DN/OD 160/162



Junction upper section
DN/OD 200/200



Junction upper section
DN/OD 160/200



Junction lower section



CONNEX-Junction Set



Spacer ring



GRP drill bit
Ø 162 or 200 mm



Threaded ring



PVC drill bit
Ø 162 or 200 mm



PP drill bit
Ø 162 or 200 mm



Threaded ring spanner



Spanner insert (adapter)

KANALROHRSYSTEM
Connex[®]

Funke Kunststoffe GmbH
Germany
Tel.: +49 2388 3071-0
info@funkegruppe.de
www.funkegruppe.com

